

**NINGBO ZHAFIR PLASTICS MACHINERY MANUFACTURING CO., LTD.**

No. 98 Guanhai Road, Chunxiao, Beilun, Ningbo, China 315800

Tel. +86-574-86182986

Fax. +86-574-86182977

E-Mail: [contact@mail.zhafir.cn](mailto:contact@mail.zhafir.cn)

[www.zhafir.cn](http://www.zhafir.cn)



# JENIUS III

SPECIFICATION | INTERNATIONAL

3,600 – 10,800 kN

ZF 2020112E-IV



# TECHNICAL DATA JE3600 III

		JE3600 III									
CLAMPING UNIT	Clamping force	kN	3600								
	Dist. between tie bars (H×V)	mm	730×730								
	Mold height max.	mm	730								
	Mold height min.	mm	280								
	Ejector stroke	mm	160								
	Ejector force	kN	110								
	Max. daylight	mm	1250								
	Mold opening stroke <sup>1</sup>	mm	970/520								
	Max. mold weight <sup>2</sup>	t	3.6								
	Min. mold dimension	mm	510×510								
Size of mold platen (H×V)	mm	1050×1050									
<b>INJECTION UNIT</b>			1400			1700			2250		
			A	B	C	A	B	C	A	B	C
Screw diameter	mm		55	60	65	60	65	70	65	70	80
Screw L/D ratio	L/D		21.8	20	18.5	21.6	20	18.6	21.5	20	17.5
Injection volume (theoretical) <sup>3</sup>	cm <sup>3</sup>		617	735	862	791	929	1077	1068	1239	1618
Injection weight (PS) <sup>4</sup>	g		562	668	785	720	845	980	972	1127	1472
Injection speed	mm/s		160			160			130		
Injection rate (PS)	g/s		332	395	463	395	463	537	376	436	570
Injection pressure <sup>5</sup>	MPa		214	180	153	210	180	155	210	180	138
	bar		2140	1800	1530	2100	1800	1550	2100	1800	1380
Holding pressure <sup>5</sup>	MPa		190	160	136	187	160	138	190	162	124
	bar		1900	1600	1360	1870	1600	1380	1900	1620	1240
Screw speed	rpm		300			250			210		
Plasticizing rate (GPPS) <sup>6</sup>	g/s		54	64	71	57	68	72	56	65	80
Plasticizing rate (HDPE) <sup>7</sup>	g/s		75	90	101	80	90	105	80	95	120
Nozzle contact force	kN		94.8			94.8			94.8		
Heating power	kW		29.8			34.4			37.8		
Connection power	kW/A		67/112			70/117			81/137		
Hopper capacity	kg		50			50			50		
Machine dimension	m		6.94×2.13×2.86			6.94×2.13×2.86			6.94×2.13×2.86		
Oil tank	l		530			530			530		
Machine weight	t		20.5			21.5			23		

NOTE: <sup>1</sup> with min. mold height / with max. mold height.

<sup>2</sup> moving platen: 2/3 of max. mold weight.

<sup>3</sup> Shot volume is the theoretical calculation value which equals to cross section area of screw cylinder or barrel plunger × screw stroke.

<sup>4</sup> Shot weight (PS) is the theoretical value converted from shot volume by melt density of PS. It is not measured.

<sup>5</sup> Injection & holding pressure are theoretical values of machine output, not actual resin pressure.

<sup>6</sup> Plasticizing capacity (GPPS): GB standard, with application of GPPS plasticizing capacity of 3-zone screws.

<sup>7</sup> Plasticizing capacity (HDPE): Euromap 19, with application of HDPE plasticizing capacity of barrier screws.

This parameter table is based on machine standard configuration;  
We reserve the right to make changes as a result of further technical advantages.

## MACHINE DIMENSIONS

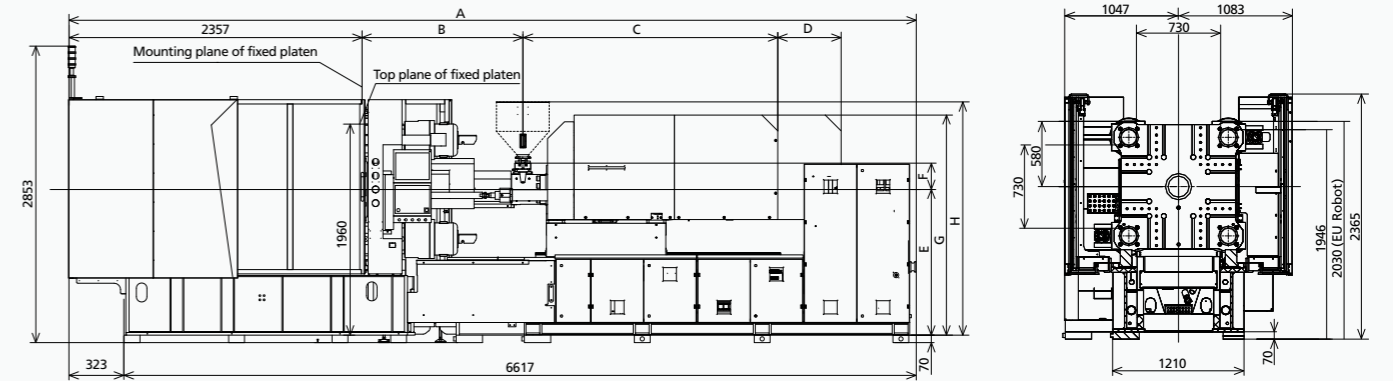

	A	B	C	D	E	F	G	H	I	J	L
1400	6940	1351	2414	500	1380	250	2085	2210	160	Ø3	SR10
1700	6940	1517	2414	500	1380	250	2085	2210	160	Ø3	SR10
2250	6940	1610	2064	500	1380	270	2079	2190	160	Ø4	SR15

## PLATEN DIMENSIONS

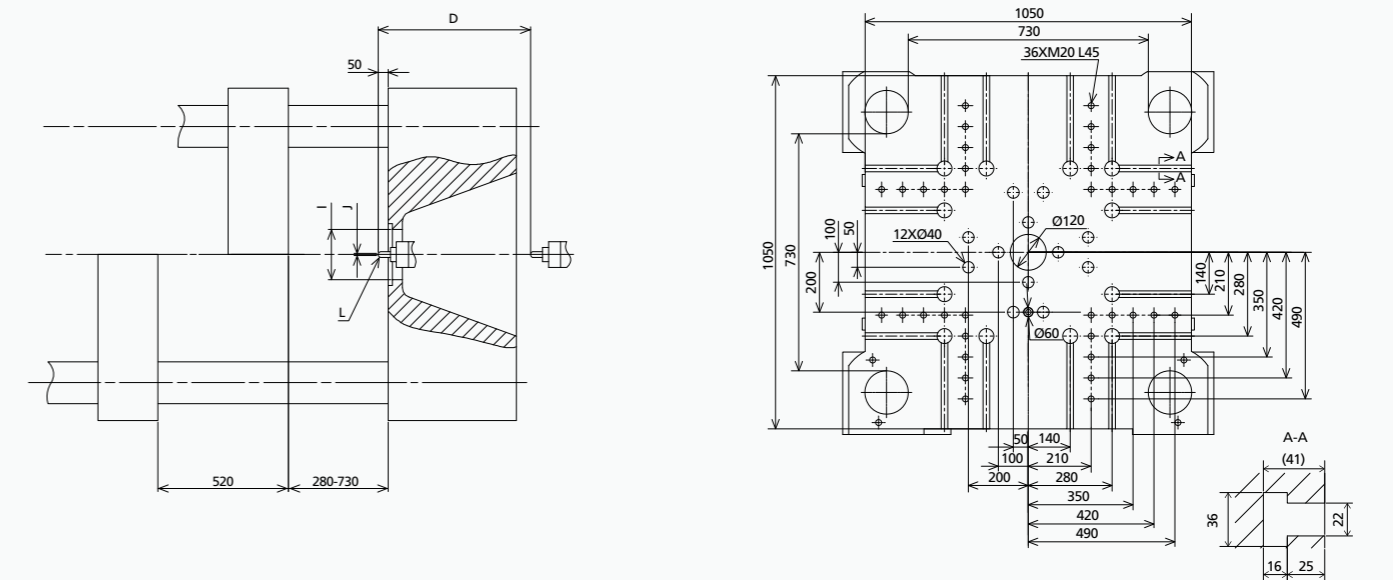

## OTHERS DIMENSIONS

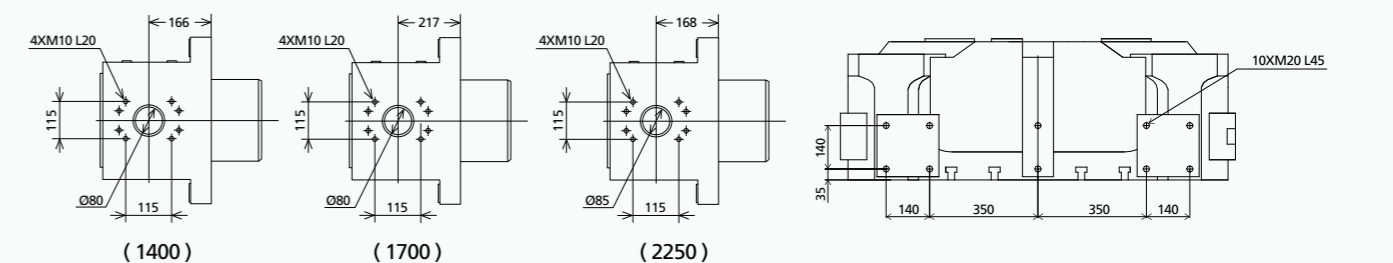

# TECHNICAL DATA JE4500 III

		JE4500 III									
CLAMPING UNIT	Clamping force	kN	4500								
	Dist. between tie bars (H×V)	mm	810×800								
	Mold height max.	mm	850								
	Mold height min.	mm	350								
	Ejector stroke	mm	250								
	Ejector force	kN	110								
	Max. daylight	mm	1400								
	Mold opening stroke <sup>1</sup>	mm	1050/550								
	Max. mold weight <sup>2</sup>	t	6.5								
	Min. mold dimension	mm	565×560								
Size of mold platen (H×V)	mm	1090×1180									
INJECTION UNIT			1700			2250			3350		
			A	B	C	A	B	C	A	B	C
Screw diameter	mm		60	65	70	65	70	80	75	80	90
Screw L/D ratio	L/D		21.6	20	18.6	21.5	20	17.5	21.3	20	17.8
Injection volume (theoretical) <sup>3</sup>	cm <sup>3</sup>		791	929	1077	1068	1239	1618	1634	1859	2353
Injection weight (PS) <sup>4</sup>	g		720	845	980	972	1127	1472	1487	1692	2141
Injection speed	mm/s		160			130			130		
Injection rate (PS)	g/s		395	463	537	376	436	570	501	570	722
Injection pressure <sup>5</sup>	MPa		210	180	155	210	180	138	205	180	142
	bar		2100	1800	1550	2100	1800	1380	2050	1800	1420
Holding pressure <sup>5</sup>	MPa		187	160	138	190	162	124	185	162	128
	bar		1870	1600	1380	1900	1620	1240	1850	1620	1280
Screw speed	rpm		250			210			185		
Plasticizing rate (GPPS) <sup>6</sup>	g/s		57	68	72	56	65	80	62	80	100
Plasticizing rate (HDPE) <sup>7</sup>	g/s		80	90	105	80	95	120	93	115	150
Nozzle contact force	kN		94.8			94.8			94.8		
Heating power	kW		34.4			37.8			45		
Connection power	kW/A		70/117			81/137			107/179		
Hopper capacity	kg		50			50			100		
Machine dimension	m		7.52×2.30×2.81			7.52×2.30×2.81			7.52×2.30×2.81		
Oil tank	l		530			530			530		
Machine weight	t		22			23			25		

NOTE: <sup>1</sup> with min. mold height / with max. mold height.  
<sup>2</sup> moving platen: 2/3 of max. mold weight.  
<sup>3</sup> Shot volume is the theoretical calculation value which equals to cross section area of screw cylinder or barrel plunger × screw stroke.  
<sup>4</sup> Shot weight (PS) is the theoretical value converted from shot volume by melt density of PS. It is not measured.  
<sup>5</sup> Injection & holding pressure are theoretical values of machine output, not actual resin pressure.  
<sup>6</sup> Plasticizing capacity (GPPS): GB standard, with application of GPPS plasticizing capacity of 3-zone screws.  
<sup>7</sup> Plasticizing capacity (HDPE): Euromap 19, with application of HDPE plasticizing capacity of barrier screws.

This parameter table is based on machine standard configuration;  
 We reserve the right to make changes as a result of further technical advantages.

## MACHINE DIMENSIONS

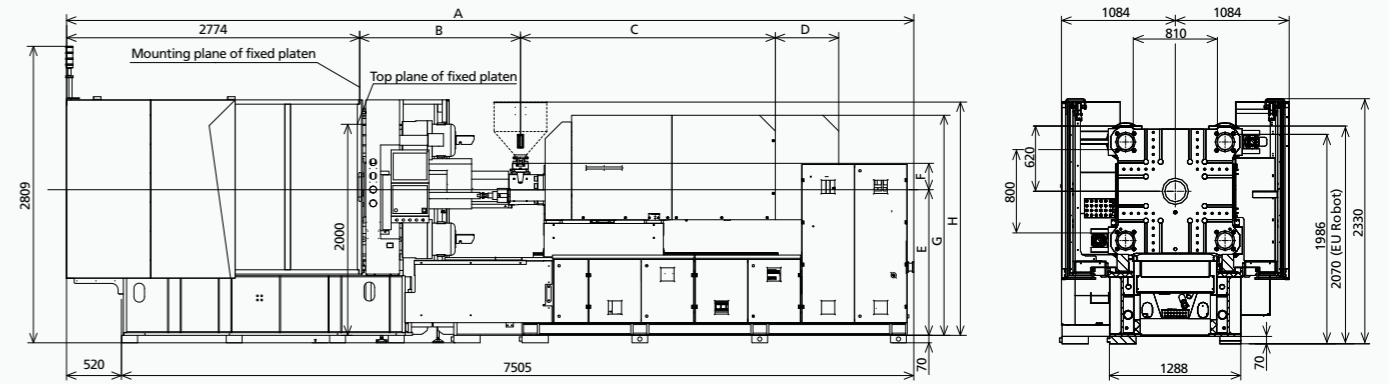

	A	B	C	D	E	F	G	H	I	J	L
1700	7520	1517	2414	600	1380	250	2085	2211	160	Ø3	SR10
2250	7520	1610	2064	600	1380	270	2105	2190	160	Ø4	SR15
3350	7520	1814	2064	600	1380	308	2042	2535	160	Ø4	SR15

## PLATEN DIMENSIONS

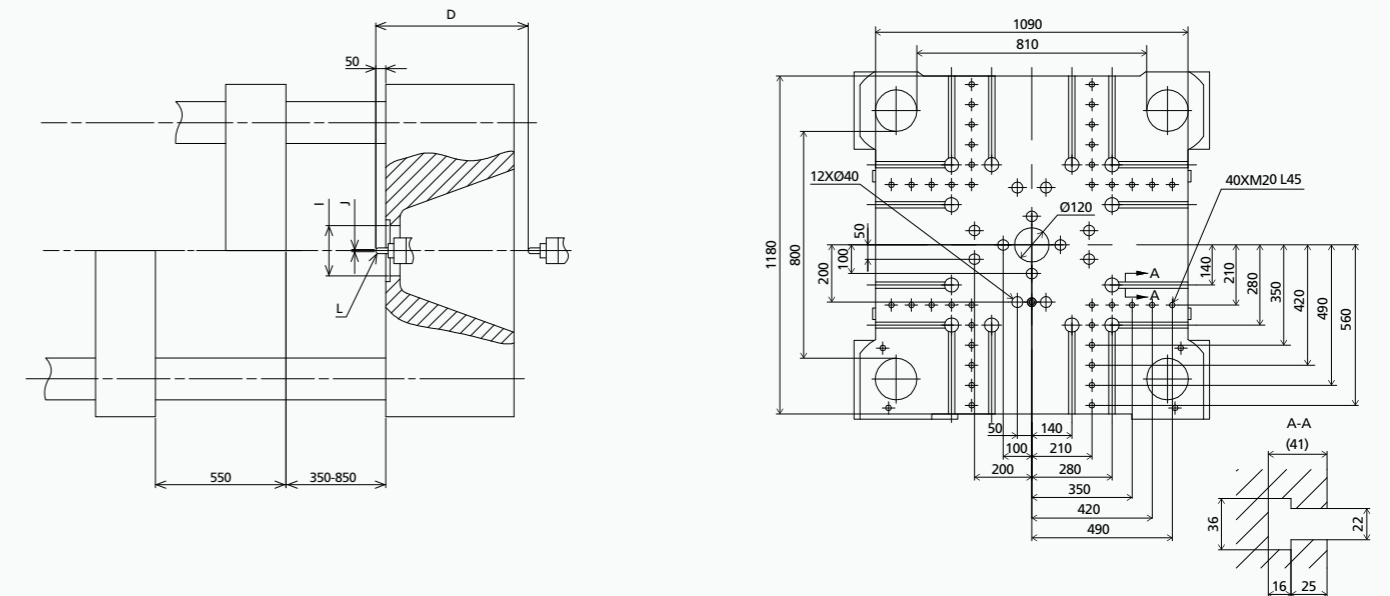

## OTHERS DIMENSIONS

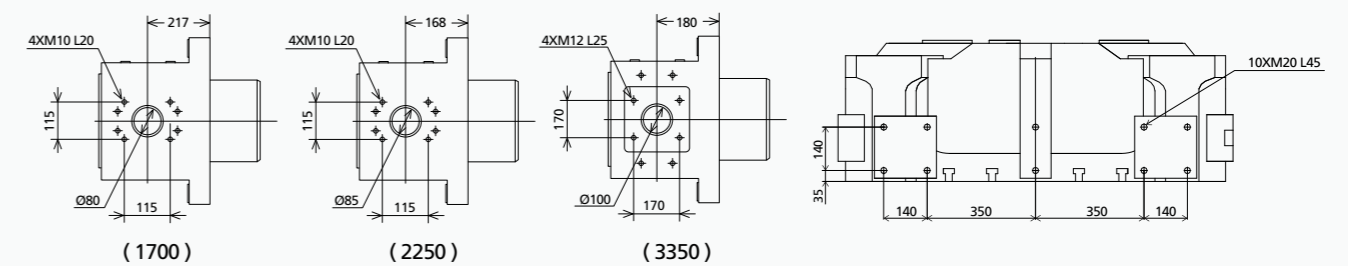

# TECHNICAL DATA JE5500 III

		JE5500 III									
CLAMPING UNIT	Clamping force	kN	5500								
	Dist. between tie bars (H×V)	mm	920×830								
	Mold height max.	mm	900								
	Mold height min.	mm	350								
	Ejector stroke	mm	250								
	Ejector force	kN	110								
	Max. daylight	mm	1650								
	Mold opening stroke <sup>1</sup>	mm	1300/750								
	Max. mold weight <sup>2</sup>	t	8								
	Min. mold dimension	mm	645×580								
Size of mold platen (H×V)	mm	1280×1260									
<b>INJECTION UNIT</b>			2250			3350			5200		
			A	B	C	A	B	C	A	B	C
Screw diameter	mm		65	70	80	75	80	90	80	90	100
Screw L/D ratio	L/D		21.5	20	17.5	21.3	20	17.8	24.8	22	19.8
Injection volume (theoretical) <sup>3</sup>	cm <sup>3</sup>		1068	1239	1618	1634	1859	2353	2261	2862	3534
Injection weight (PS) <sup>4</sup>	g		972	1127	1472	1487	1692	2141	2058	2605	3216
Injection speed	mm/s		130			130			120		
Injection rate (PS)	g/s		376	436	570	501	570	722	527	667	823
Injection pressure <sup>5</sup>	MPa		210	180	138	205	180	142	227	180	145
	bar		2100	1800	1380	2050	1800	1420	2270	1800	1450
Holding pressure <sup>5</sup>	MPa		190	162	124	185	162	128	204	162	131
	bar		1900	1620	1240	1850	1620	1280	2040	1620	1310
Screw speed	rpm		210			185			160		
Plasticizing rate (GPPS) <sup>6</sup>	g/s		56	65	80	62	80	100	78	98	120
Plasticizing rate (HDPE) <sup>7</sup>	g/s		80	95	120	93	115	150	115	146	180
Nozzle contact force	kN		94.8			94.8			94.8		
Heating power	kW		37.8			45			54.3		
Connection power	kW/A		81/137			107/179			141/237		
Hopper capacity	kg		50			100			100		
Machine dimension	m		8.34×2.54×2.76			8.34×2.54×2.76			8.34×2.54×2.76		
Oil tank	l		530			530			530		
Machine weight	t		25			27			30		

NOTE: <sup>1</sup> with min. mold height / with max. mold height.

<sup>2</sup> moving platen: 2/3 of max. mold weight.

<sup>3</sup> Shot volume is the theoretical calculation value which equals to cross section area of screw cylinder or barrel plunger × screw stroke.

<sup>4</sup> Shot weight (PS) is the theoretical value converted from shot volume by melt density of PS. It is not measured.

<sup>5</sup> Injection & holding pressure are theoretical values of machine output, not actual resin pressure.

<sup>6</sup> Plasticizing capacity (GPPS): GB standard, with application of GPPS plasticizing capacity of 3-zone screws.

<sup>7</sup> Plasticizing capacity (HDPE): Euromap 19, with application of HDPE plasticizing capacity of barrier screws.

This parameter table is based on machine standard configuration;  
We reserve the right to make changes as a result of further technical advantages.

## MACHINE DIMENSIONS

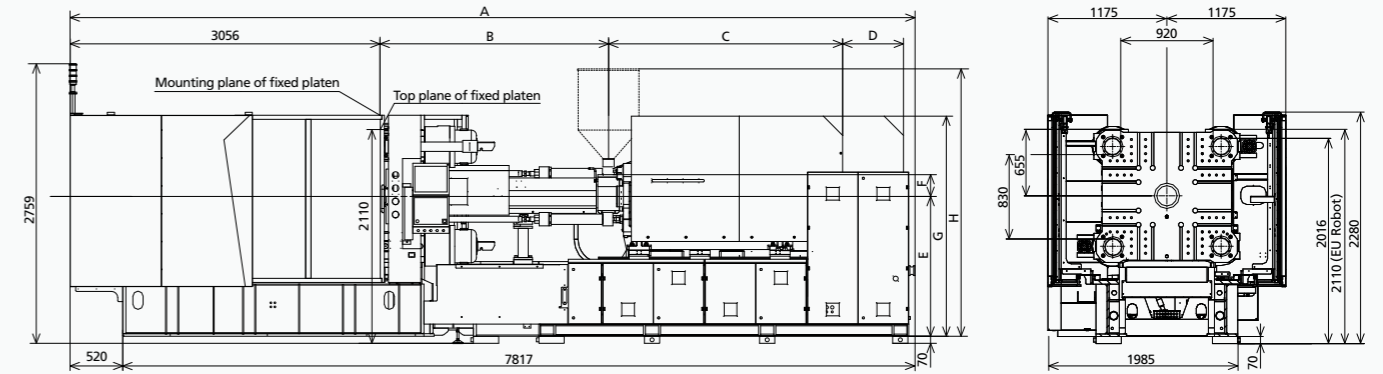

	A	B	C	D	E	F	G	H	I	J	L
2250	8337	1610	2064	600	1380	270	2105	2190	160	Ø4	SR15
3350	8337	1814	2064	600	1380	308	2042	2535	160	Ø4	SR15
5200	8337	2256	2310	600	1380	215	2172	2438	160	Ø4	SR15

## PLATEN DIMENSIONS

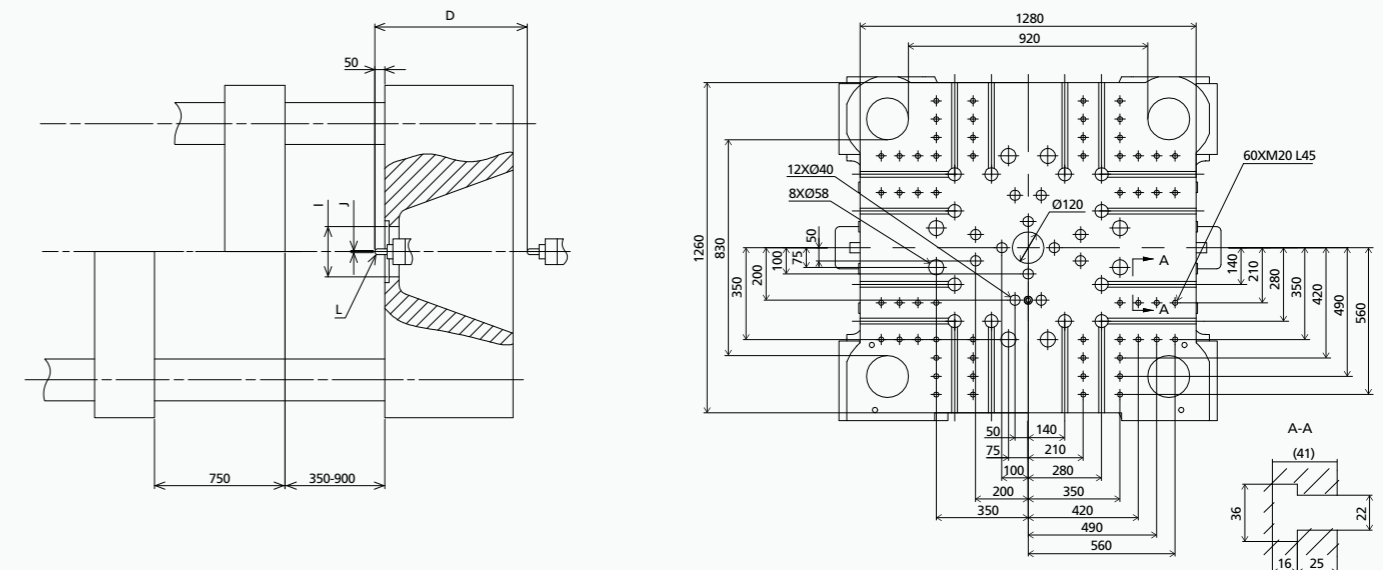

## OTHERS DIMENSIONS

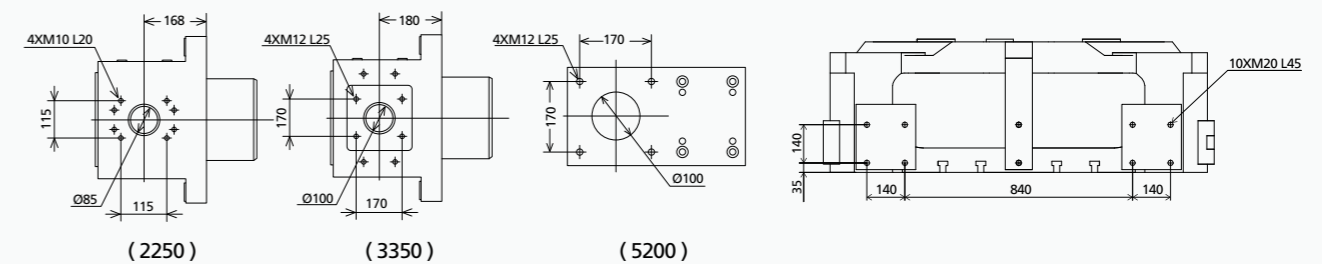

# TECHNICAL DATA JE6500 III

		JE6500 III									
CLAMPING UNIT	Clamping force	kN	6500								
	Dist. between tie bars (H×V)	mm	1040×910								
	Mold height max.	mm	950								
	Mold height min.	mm	400								
	Ejector stroke	mm	250								
	Ejector force	kN	110								
	Max. daylight	mm	1750								
	Mold opening stroke <sup>1</sup>	mm	1350/800								
	Max. mold weight <sup>2</sup>	t	9.5								
	Min. mold dimension	mm	730×635								
Size of mold platen (H×V)	mm	1400×1350									
INJECTION UNIT			2250			3350			5200		
			A	B	C	A	B	C	A	B	C
Screw diameter	mm		65	70	80	75	80	90	80	90	100
Screw L/D ratio	L/D		21.5	20	17.5	21.3	20	17.8	24.8	22	19.8
Injection volume (theoretical) <sup>3</sup>	cm <sup>3</sup>		1068	1239	1618	1634	1859	2353	2261	2862	3534
Injection weight (PS) <sup>4</sup>	g		972	1127	1472	1487	1692	2141	2058	2605	3216
Injection speed	mm/s		130			130			120		
Injection rate (PS)	g/s		376	436	570	501	570	722	527	667	823
Injection pressure <sup>5</sup>	MPa		210	180	138	205	180	142	227	180	145
	bar		2100	1800	1380	2050	1800	1420	2270	1800	1450
Holding pressure <sup>5</sup>	MPa		190	162	124	185	162	128	204	162	131
	bar		1900	1620	1240	1850	1620	1280	2040	1620	1310
Screw speed	rpm		210			185			160		
Plasticizing rate (GPPS) <sup>6</sup>	g/s		56	65	80	62	80	100	78	98	120
Plasticizing rate (HDPE) <sup>7</sup>	g/s		80	95	120	93	115	150	115	146	180
Nozzle contact force	kN		94.8			94.8			94.8		
Heating power	kW		37.8			45			54.3		
Connection power	kW/A		81/137			107/179			141/237		
Hopper capacity	kg		50			100			100		
Machine dimension	m		8.50×2.61×2.71			8.50×2.61×2.71			8.50×2.61×2.71		
Oil tank	l		530			530			530		
Machine weight	t		28			30			33		

NOTE: <sup>1</sup> with min. mold height / with max. mold height.

<sup>2</sup> moving platen: 2/3 of max. mold weight.

<sup>3</sup> Shot volume is the theoretical calculation value which equals to cross section area of screw cylinder or barrel plunger × screw stroke.

<sup>4</sup> Shot weight (PS) is the theoretical value converted from shot volume by melt density of PS. It is not measured.

<sup>5</sup> Injection & holding pressure are theoretical values of machine output, not actual resin pressure.

<sup>6</sup> Plasticizing capacity (GPPS): GB standard, with application of GPPS plasticizing capacity of 3-zone screws.

<sup>7</sup> Plasticizing capacity (HDPE): Euromap 19, with application of HDPE plasticizing capacity of barrier screws.

This parameter table is based on machine standard configuration;  
We reserve the right to make changes as a result of further technical advantages.

## MACHINE DIMENSIONS

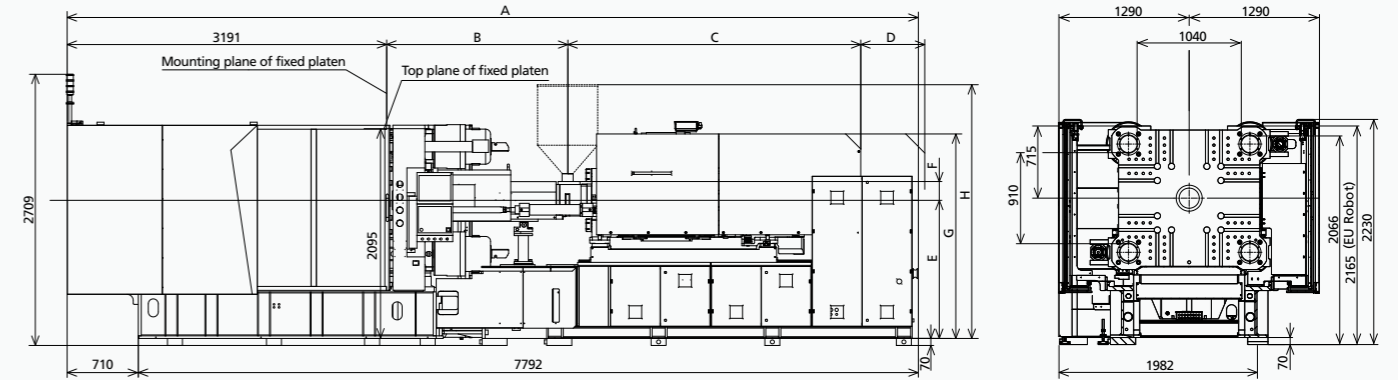

	A	B	C	D	E	F	G	H	I	J	L
2250	8502	1610	2064	600	1380	270	2105	2190	200	Ø4	SR15
3350	8502	1814	2064	600	1380	308	2042	2535	200	Ø4	SR15
5200	8502	2256	2310	600	1380	215	2172	2438	200	Ø4	SR15

## PLATEN DIMENSIONS

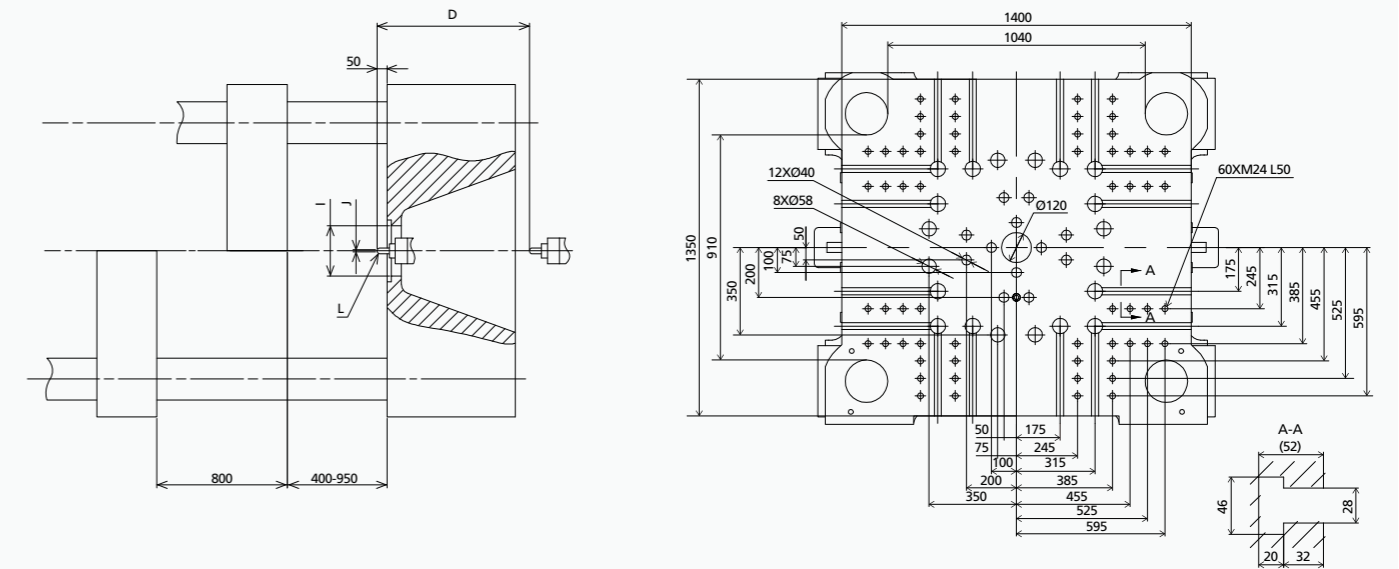

## OTHERS DIMENSIONS

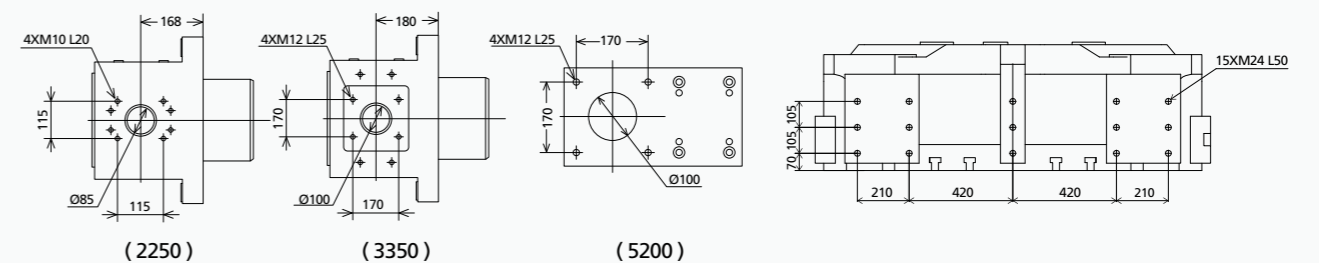

# TECHNICAL DATA JE7500 III

		JE7500 III									
CLAMPING UNIT	Clamping force	kN	7500								
	Dist. between tie bars (H×V)	mm	1110×960								
	Mold height max.	mm	950								
	Mold height min.	mm	450								
	Ejector stroke	mm	300								
	Ejector force	kN	195								
	Max. daylight	mm	1850								
	Mold opening stroke <sup>1</sup>	mm	1400/900								
	Max. mold weight <sup>2</sup>	t	11								
	Min. mold dimension	mm	775×670								
Size of mold platen (H×V)	mm	1510×1440									
<b>INJECTION UNIT</b>			2250			3350			5200		
			A	B	C	A	B	C	A	B	C
Screw diameter	mm		65	70	80	75	80	90	80	90	100
Screw L/D ratio	L/D		21.5	20	17.5	21.3	20	17.8	24.8	22	19.8
Injection volume (theoretical) <sup>3</sup>	cm <sup>3</sup>		1068	1239	1618	1634	1859	2353	2261	2862	3534
Injection weight (PS) <sup>4</sup>	g		972	1127	1472	1487	1692	2141	2058	2605	3216
Injection speed	mm/s		130			130			120		
Injection rate (PS)	g/s		376	436	570	501	570	722	527	667	823
Injection pressure <sup>5</sup>	MPa		210	180	138	205	180	142	227	180	145
	bar		2100	1800	1380	2050	1800	1420	2270	1800	1450
Holding pressure <sup>5</sup>	MPa		190	162	124	185	162	128	204	162	131
	bar		1900	1620	1240	1850	1620	1280	2040	1620	1310
Screw speed	rpm		210			185			160		
Plasticizing rate (GPPS) <sup>6</sup>	g/s		56	65	80	62	80	100	78	98	120
Plasticizing rate (HDPE) <sup>7</sup>	g/s		80	95	120	93	115	150	115	146	180
Nozzle contact force	kN		94.8			94.8			94.8		
Heating power	kW		37.8			45			54.3		
Connection power	kW/A		81/137			107/179			141/237		
Hopper capacity	kg		50			100			100		
Machine dimension	m		8.81×2.86×2.73			8.81×2.86×2.73			8.81×2.86×2.73		
Oil tank	l		530			530			530		
Machine weight	t		30			32			35		

NOTE: <sup>1</sup> with min. mold height / with max. mold height.

<sup>2</sup> moving platen: 2/3 of max. mold weight.

<sup>3</sup> Shot volume is the theoretical calculation value which equals to cross section area of screw cylinder or barrel plunger × screw stroke.

<sup>4</sup> Shot weight (PS) is the theoretical value converted from shot volume by melt density of PS. It is not measured.

<sup>5</sup> Injection & holding pressure are theoretical values of machine output, not actual resin pressure.

<sup>6</sup> Plasticizing capacity (GPPS): GB standard, with application of GPPS plasticizing capacity of 3-zone screws.

<sup>7</sup> Plasticizing capacity (HDPE): Euromap 19, with application of HDPE plasticizing capacity of barrier screws.

This parameter table is based on machine standard configuration;  
We reserve the right to make changes as a result of further technical advantages.

## MACHINE DIMENSIONS

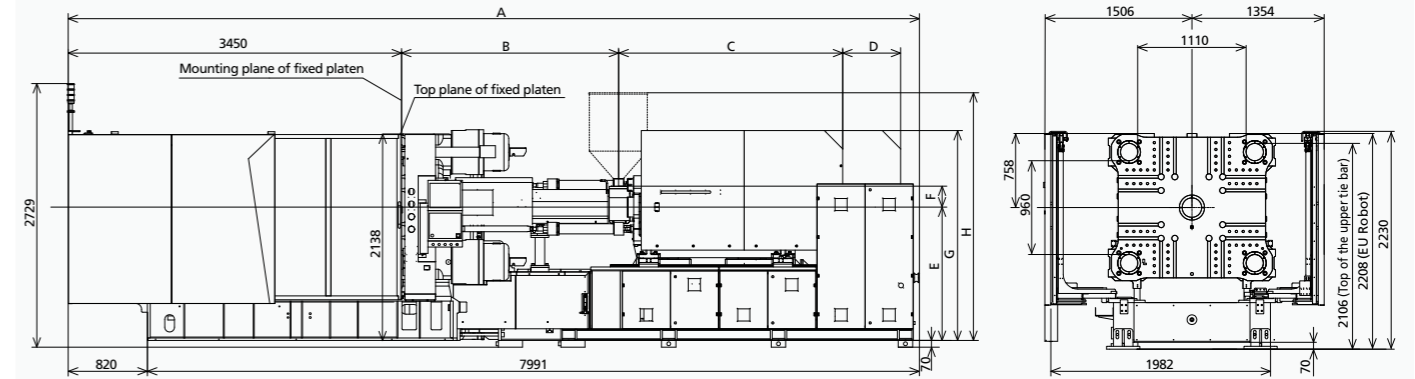

	A	B	C	D	E	F	G	H	I	J	L
2250	8811	1610	2064	660	1380	270	2105	2190	200	Ø4	SR15
3350	8811	1814	2064	660	1380	308	2042	2535	200	Ø4	SR15
5200	8811	2256	2310	660	1380	215	2172	2438	200	Ø4	SR15

## PLATEN DIMENSIONS

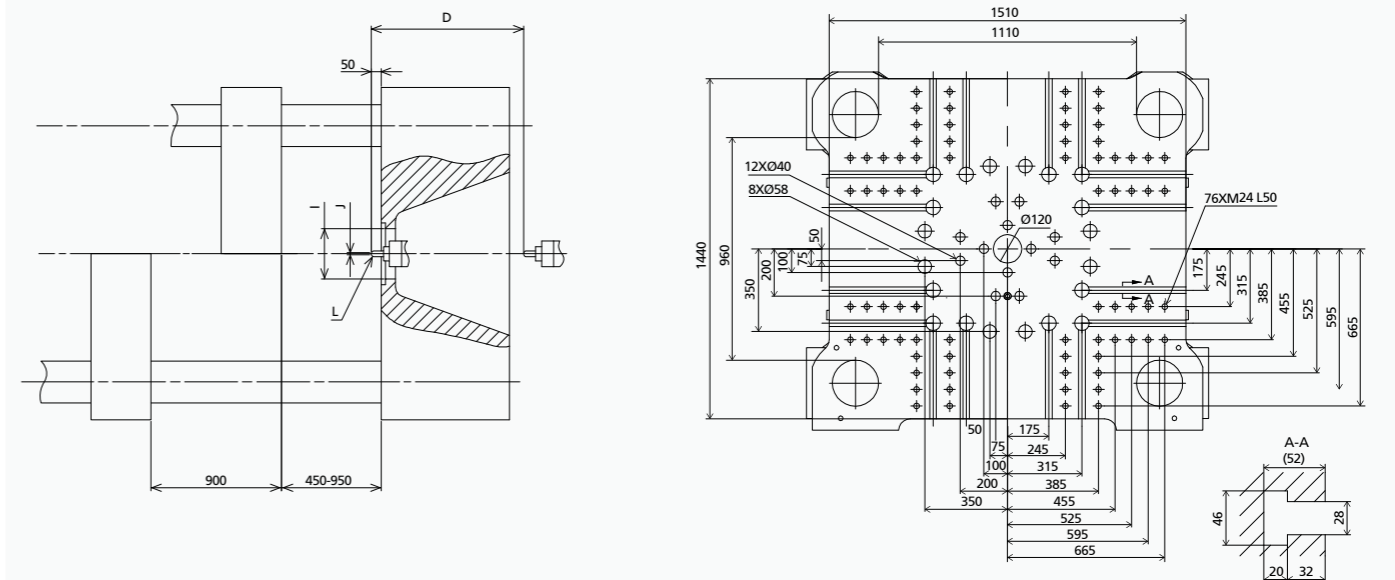

## OTHERS DIMENSIONS

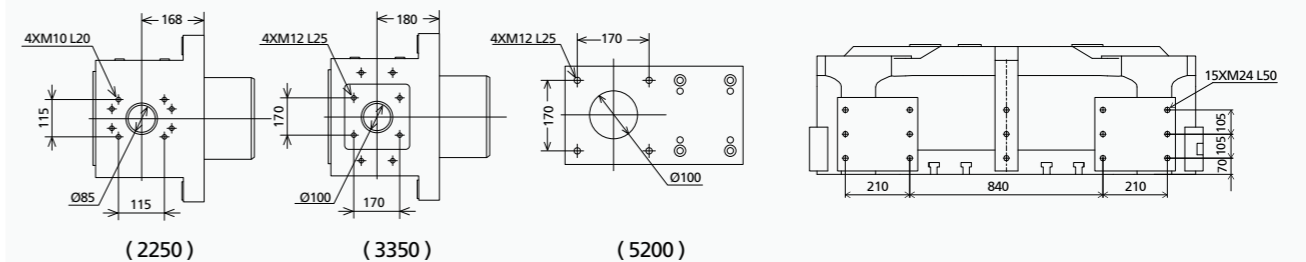

# TECHNICAL DATA JE9000 III

		JE9000 III									
CLAMPING UNIT	Clamping force	kN	9000								
	Dist. between tie bars (H×V)	mm	1180×1000								
	Mold height max.	mm	1100								
	Mold height min.	mm	500								
	Ejector stroke	mm	300								
	Ejector force	kN	195								
	Max. daylight	mm	2100								
	Mold opening stroke <sup>1</sup>	mm	1600/1000								
	Max. mold weight <sup>2</sup>	t	13								
	Min. mold dimension	mm	825×700								
Size of mold platen (H×V)	mm	1560×1520									
<b>INJECTION UNIT</b>			3350			5200			7000		
			A	B	C	A	B	C	A	B	C
Screw diameter	mm		75	80	90	80	90	100	90	100	110
Screw L/D ratio	L/D		21.3	20	17.8	24.8	22	19.8	24.4	22	20
Injection volume (theoretical) <sup>3</sup>	cm <sup>3</sup>		1634	1859	2353	2261	2862	3534	2989	3691	4466
Injection weight (PS) <sup>4</sup>	g		1487	1692	2141	2058	2605	3216	2720	3359	4064
Injection speed	mm/s		130			120			120		
Injection rate (PS)	g/s		501	570	722	527	667	823	667	823	996
Injection pressure <sup>5</sup>	MPa		205	180	142	227	180	145	234	190	157
	bar		2050	1800	1420	2270	1800	1450	2340	1900	1570
Holding pressure <sup>5</sup>	MPa		185	162	128	204	162	131	200	162	134
	bar		1850	1620	1280	2040	1620	1310	2000	1620	1340
Screw speed	rpm		185			160			150		
Plasticizing rate (GPPS) <sup>6</sup>	g/s		62	80	100	78	98	120	100	120	145
Plasticizing rate (HDPE) <sup>7</sup>	g/s		93	115	150	115	146	180	147	180	214
Nozzle contact force	kN		94.8			94.8			94.8		
Heating power	kW		45			54.3			75.6		
Connection power	kW/A		107/179			141/237			155/259		
Hopper capacity	kg		100			100			100		
Machine dimension	m		9.66×3.20×2.69			9.66×3.20×2.69			9.66×3.20×2.69		
Oil tank	l		670			670			670		
Machine weight	t		40			43			50		

- NOTE: <sup>1</sup> with min. mold height / with max. mold height.  
<sup>2</sup> moving platen: 2/3 of max. mold weight.  
<sup>3</sup> Shot volume is the theoretical calculation value which equals to cross section area of screw cylinder or barrel plunger × screw stroke.  
<sup>4</sup> Shot weight (PS) is the theoretical value converted from shot volume by melt density of PS. It is not measured.  
<sup>5</sup> Injection & holding pressure are theoretical values of machine output, not actual resin pressure.  
<sup>6</sup> Plasticizing capacity (GPPS): GB standard, with application of GPPS plasticizing capacity of 3-zone screws.  
<sup>7</sup> Plasticizing capacity (HDPE): Euromap 19, with application of HDPE plasticizing capacity of barrier screws.

## MACHINE DIMENSIONS

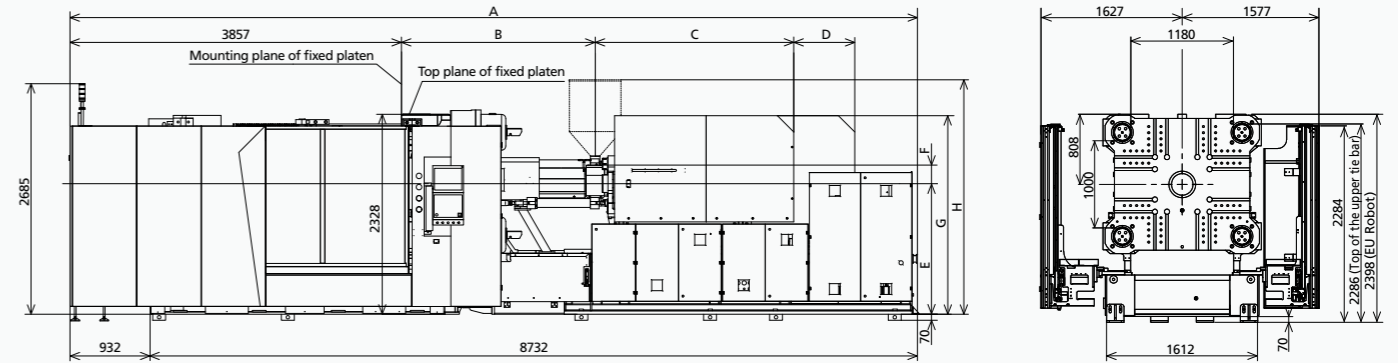

	A	B	C	D	E	F	G	H	I	J	L
3350	9664	1814	2064	710	1520	308	2245	2535	200	Ø4	SR15
5200	9664	2256	2310	710	1520	215	2312	2730	200	Ø4	SR15
7000	9664	2504	2734	710	1520	233	2312	2747	200	Ø6	SR20

## PLATEN DIMENSIONS

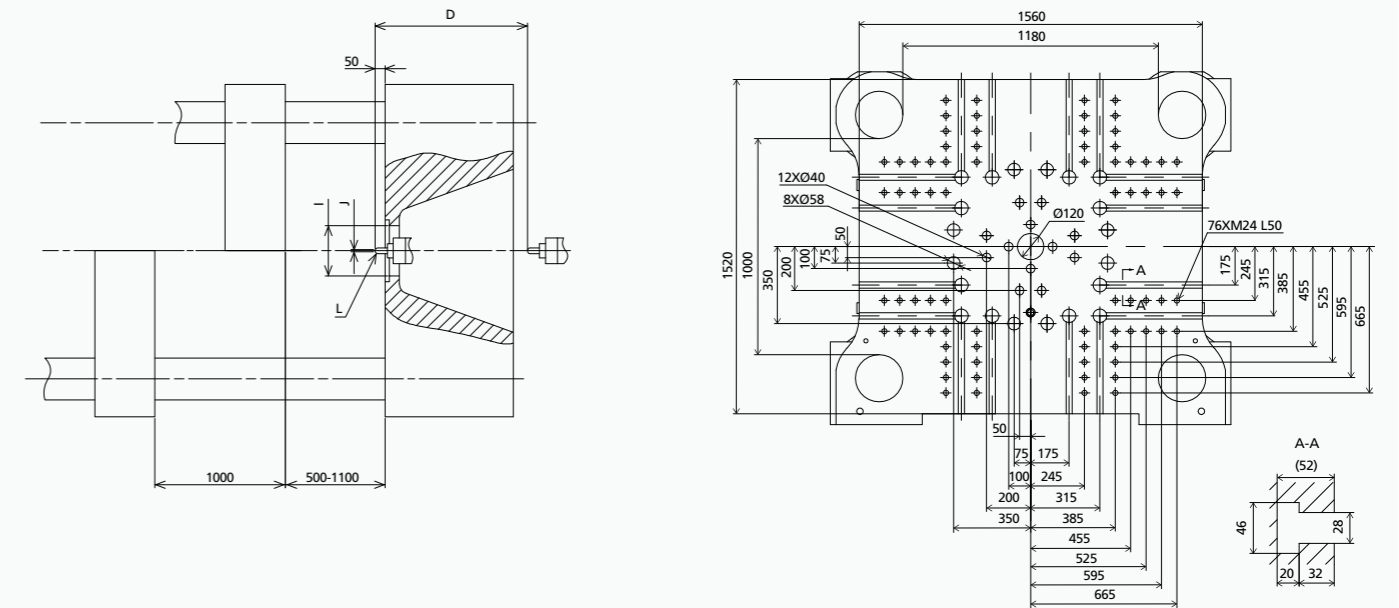

## OTHERS DIMENSIONS

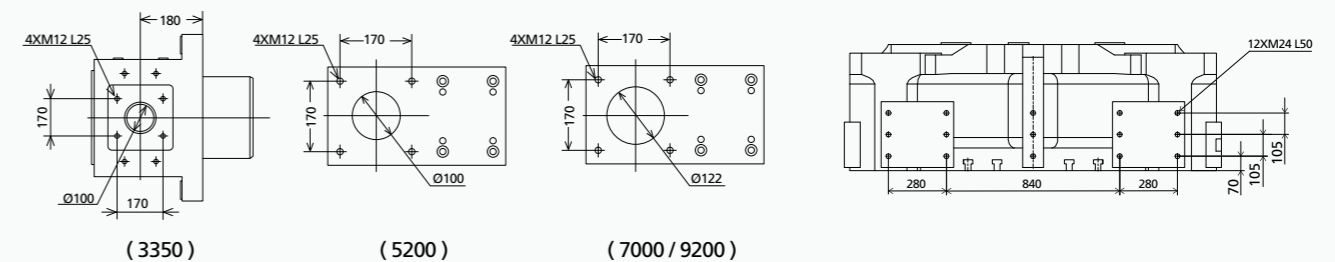

This parameter table is based on machine standard configuration;  
 We reserve the right to make changes as a result of further technical advantages.

# TECHNICAL DATA JE10800 III

		JE10800 III									
CLAMPING UNIT	Clamping force	kN	10800								
	Dist. between tie bars (H×V)	mm	1260×1100								
	Mold height max.	mm	1200								
	Mold height min.	mm	500								
	Ejector stroke	mm	350								
	Ejector force	kN	230								
	Max. daylight	mm	2400								
	Mold opening stroke <sup>1</sup>	mm	1900/1200								
	Max. mold weight <sup>2</sup>	t	16								
	Min. mold dimension	mm	880×770								
Size of mold platen (H×V)	mm	1700×1660									
<b>INJECTION UNIT</b>			3350			5200			7000		
			A	B	C	A	B	C	A	B	C
Screw diameter	mm		75	80	90	80	90	100	90	100	110
Screw L/D ratio	L/D		21.3	20	17.8	24.8	22	19.8	24.4	22	20
Injection volume (theoretical) <sup>3</sup>	cm <sup>3</sup>		1634	1859	2353	2261	2862	3534	2989	3691	4466
Injection weight (PS) <sup>4</sup>	g		1487	1692	2141	2058	2605	3216	2720	3359	4064
Injection speed	mm/s		130			120			120		
Injection rate (PS)	g/s		501	570	722	527	667	823	667	823	996
Injection pressure <sup>5</sup>	MPa		205	180	142	227	180	145	234	190	157
	bar		2050	1800	1420	2270	1800	1450	2340	1900	1570
Holding pressure <sup>5</sup>	MPa		185	162	128	204	162	131	200	162	134
	bar		1850	1620	1280	2040	1620	1310	2000	1620	1340
Screw speed	rpm		185			160			150		
Plasticizing rate (GPPS) <sup>6</sup>	g/s		62	80	100	78	98	120	100	120	145
Plasticizing rate (HDPE) <sup>7</sup>	g/s		93	115	150	115	146	180	147	180	214
Nozzle contact force	kN		94.8			94.8			94.8		
Heating power	kW		45			54.3			75.6		
Connection power	kW/A		107/179			141/237			155/259		
Hopper capacity	kg		100			100			100		
Machine dimension	m		9.85×3.30×2.67			9.85×3.30×2.67			9.85×3.30×2.67		
Oil tank	l		670			670			670		
Machine weight	t		46			49			56		

- NOTE: <sup>1</sup> with min. mold height / with max. mold height.  
<sup>2</sup> moving platen: 2/3 of max. mold weight.  
<sup>3</sup> Shot volume is the theoretical calculation value which equals to cross section area of screw cylinder or barrel plunger × screw stroke.  
<sup>4</sup> Shot weight (PS) is the theoretical value converted from shot volume by melt density of PS. It is not measured.  
<sup>5</sup> Injection & holding pressure are theoretical values of machine output, not actual resin pressure.  
<sup>6</sup> Plasticizing capacity (GPPS): GB standard, with application of GPPS plasticizing capacity of 3-zone screws.  
<sup>7</sup> Plasticizing capacity (HDPE): Euromap 19, with application of HDPE plasticizing capacity of barrier screws.

## MACHINE DIMENSIONS

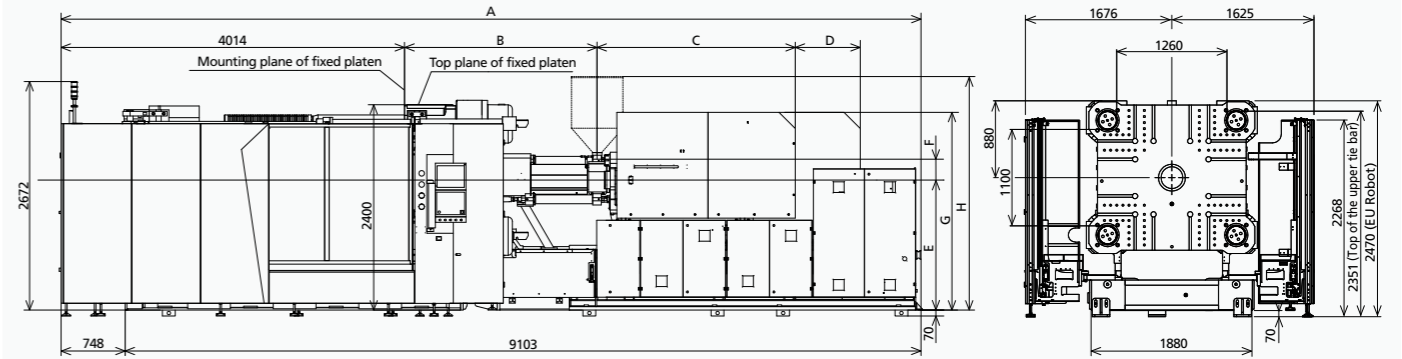

	A	B	C	D	E	F	G	H	I	J	L
3350	9851	1821	2064	760	1520	307	2245	2535	200	Ø4	SR15
5200	9851	2256	2310	760	1520	215	2312	2730	200	Ø4	SR15
7000	9851	2504	2734	760	1520	233	2312	2747	200	Ø6	SR20

## PLATEN DIMENSIONS

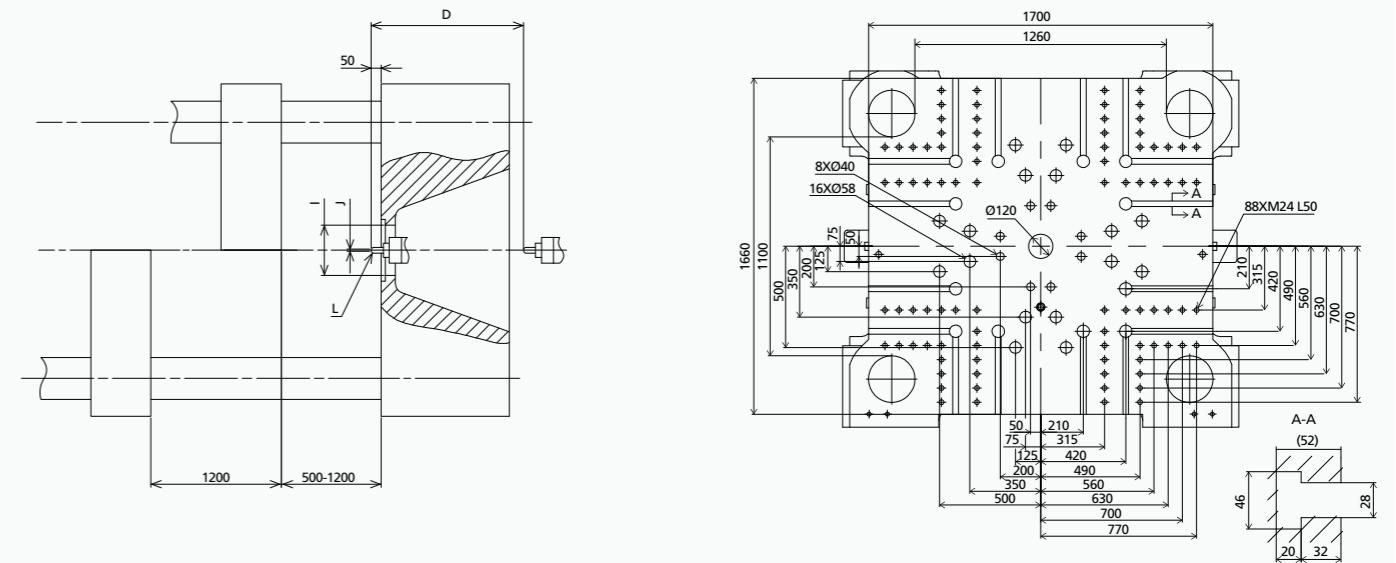

## OTHERS DIMENSIONS

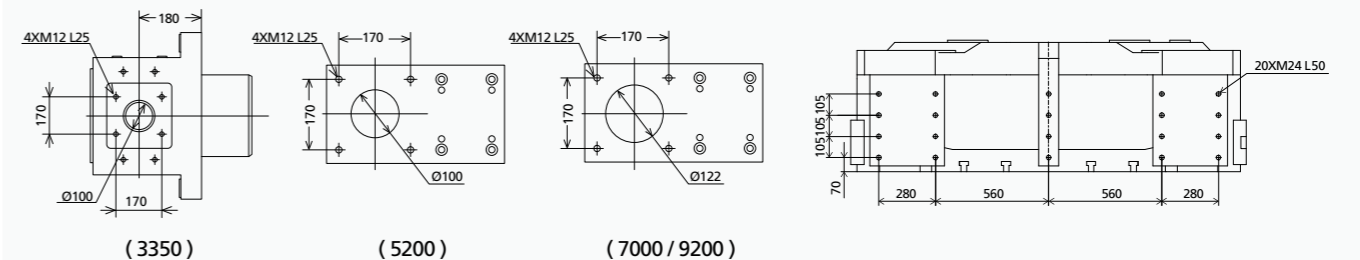

This parameter table is based on machine standard configuration;  
 We reserve the right to make changes as a result of further technical advantages.



# PLATEN LAYOUT JE3600 III

**EUROPEAN VERSION**  
FIXED PLATEN

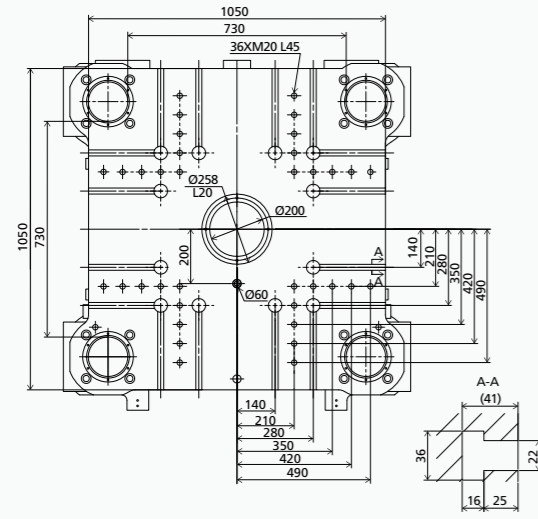

MOVABLE PLATEN

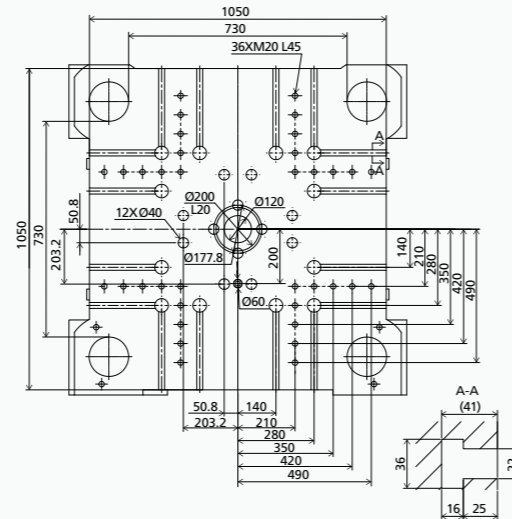

**AMERICAN VERSION**  
FIXED PLATEN

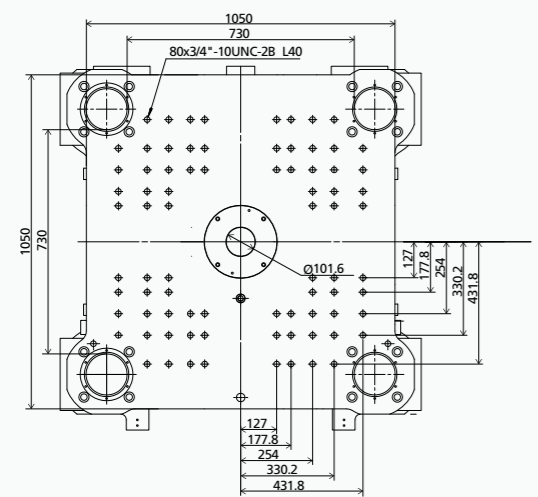

MOVABLE PLATEN

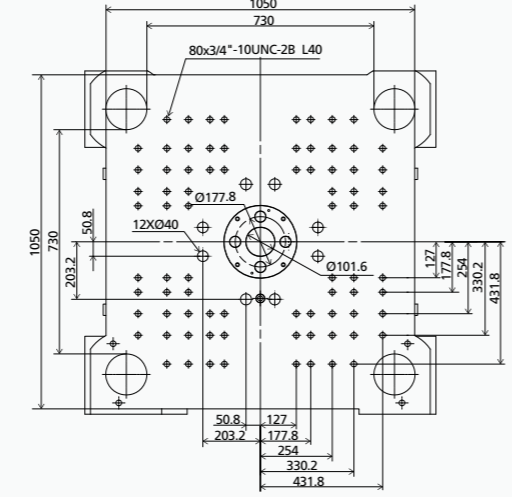

**JAPANESE VERSION**  
FIXED PLATEN

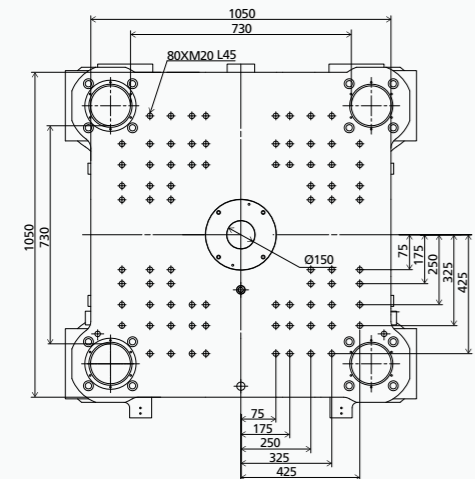

MOVABLE PLATEN

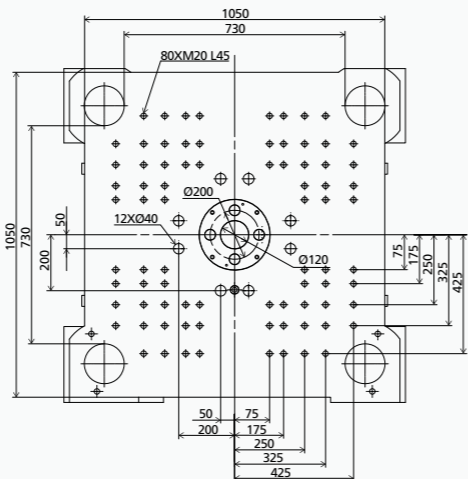

**EUROPEAN VERSION**  
FIXED PLATEN

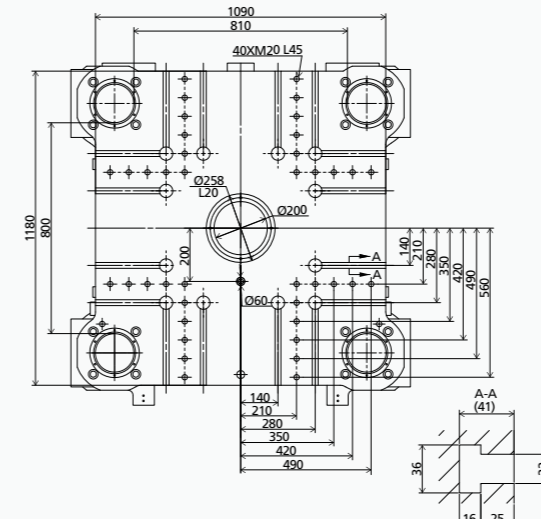

MOVABLE PLATEN

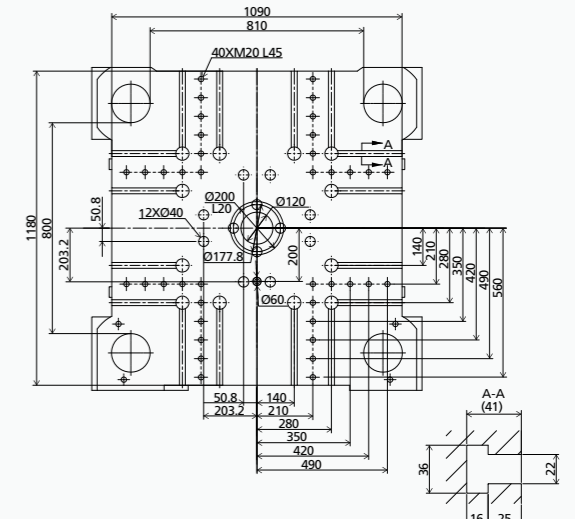

**AMERICAN VERSION**  
FIXED PLATEN

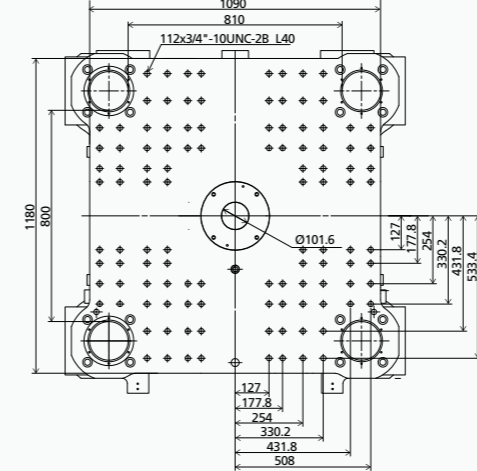

MOVABLE PLATEN

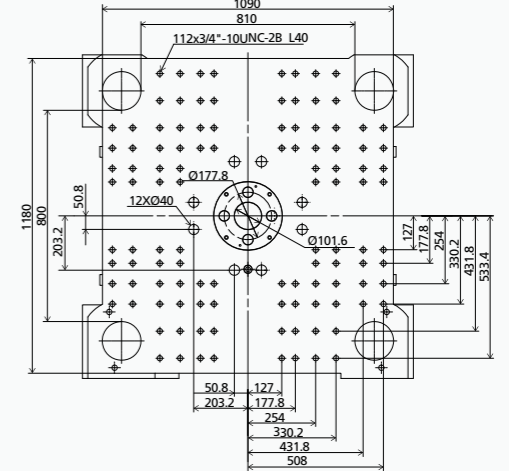

**JAPANESE VERSION**  
FIXED PLATEN

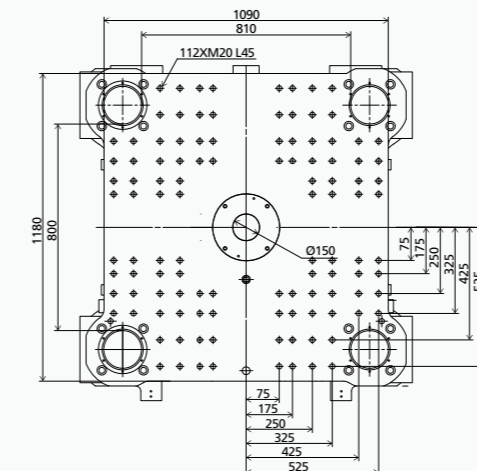

MOVABLE PLATEN

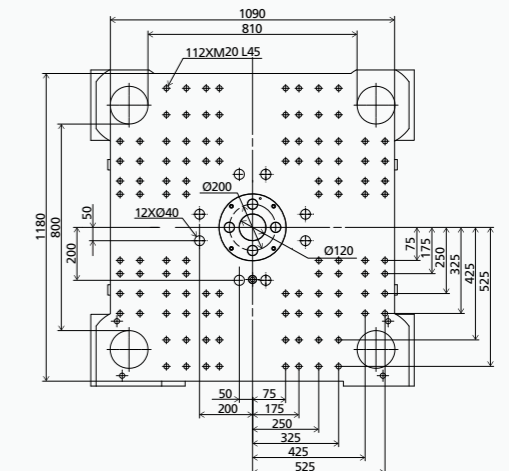

We reserve the right to make changes as a result of further technical advantages.

# PLATEN LAYOUT JE5500 III

## EUROPEAN VERSION FIXED PLATEN

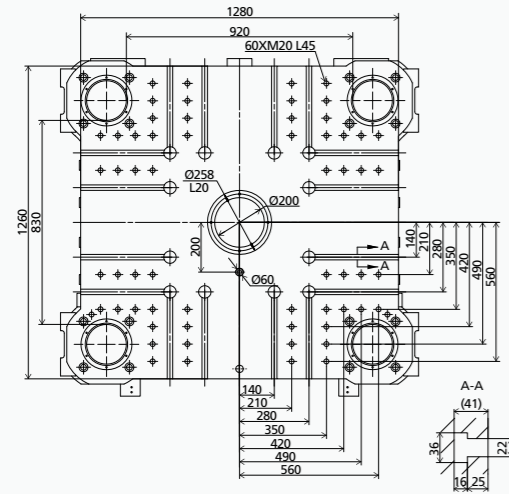

## MOVABLE PLATEN

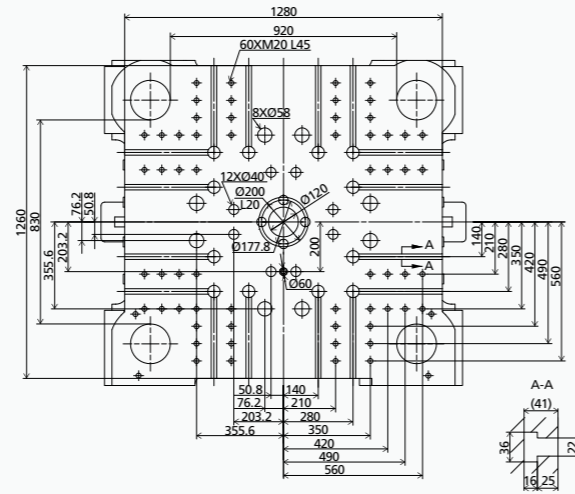

## AMERICAN VERSION FIXED PLATEN

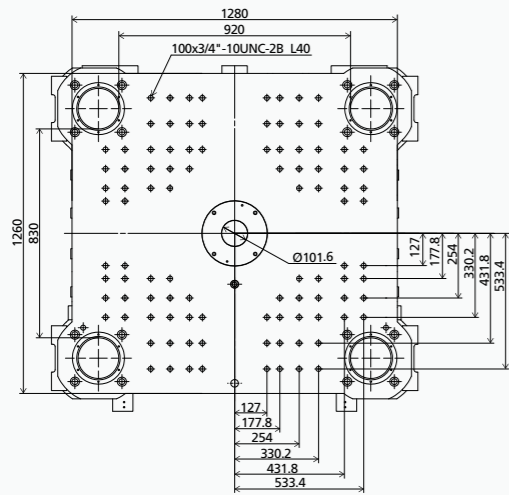

## MOVABLE PLATEN

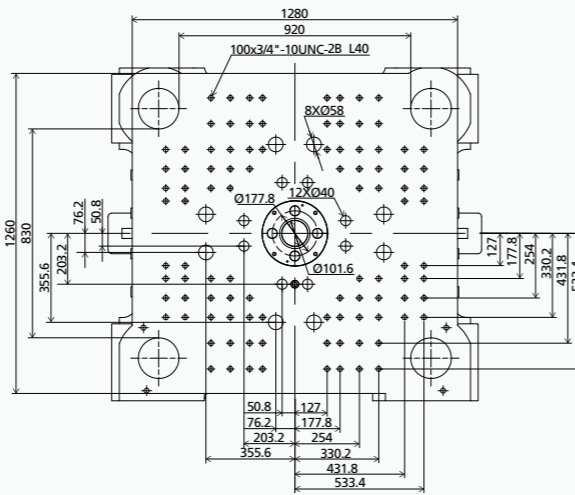

## JAPANESE VERSION FIXED PLATEN

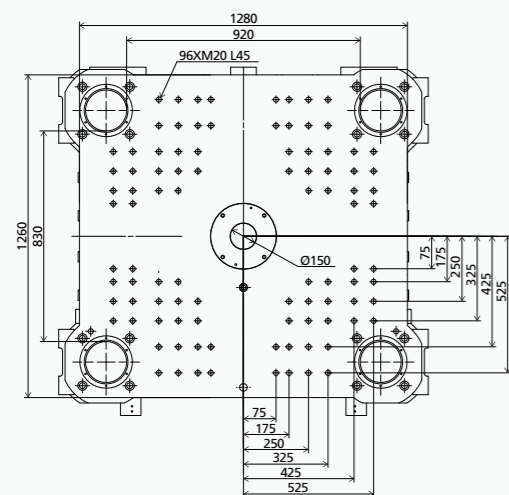

## MOVABLE PLATEN

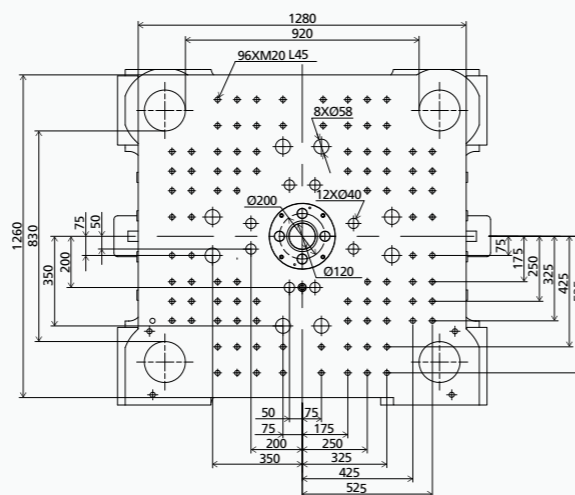

# PLATEN LAYOUT JE6500 III

## EUROPEAN VERSION FIXED PLATEN

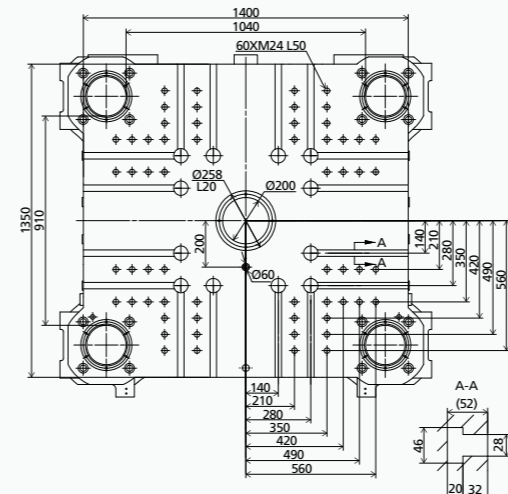

## MOVABLE PLATEN

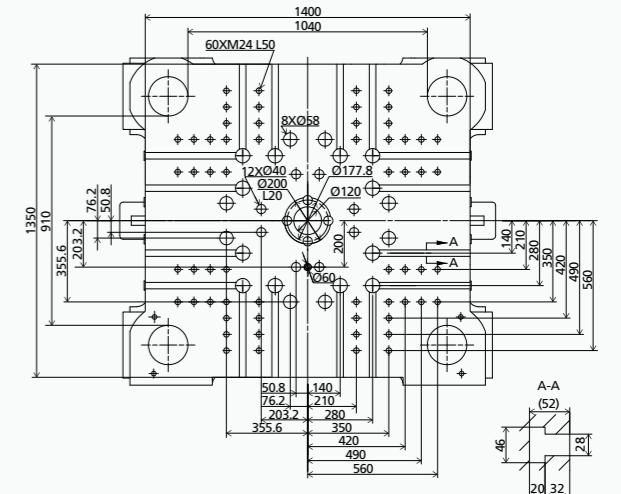

## AMERICAN VERSION FIXED PLATEN

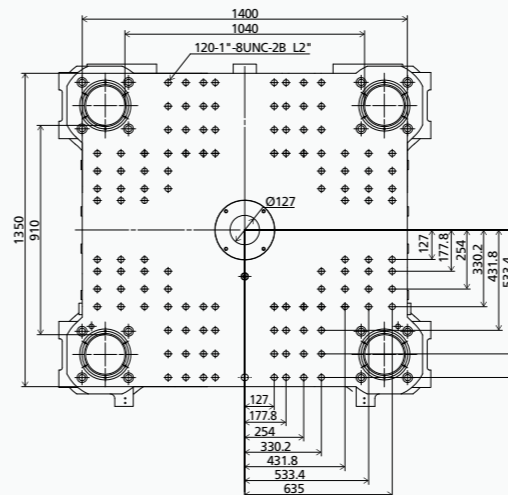

## MOVABLE PLATEN

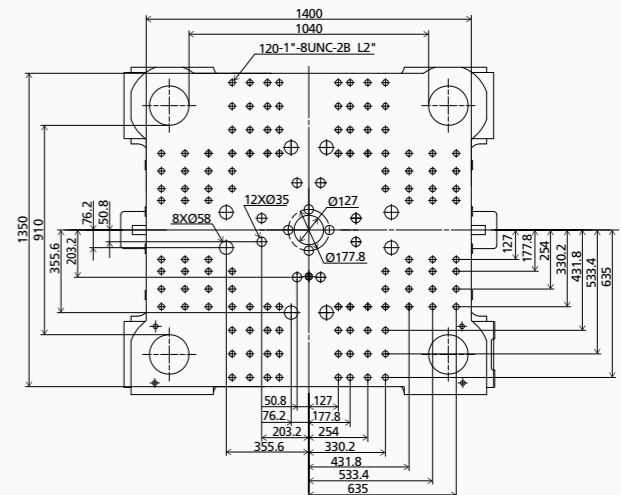

## JAPANESE VERSION FIXED PLATEN

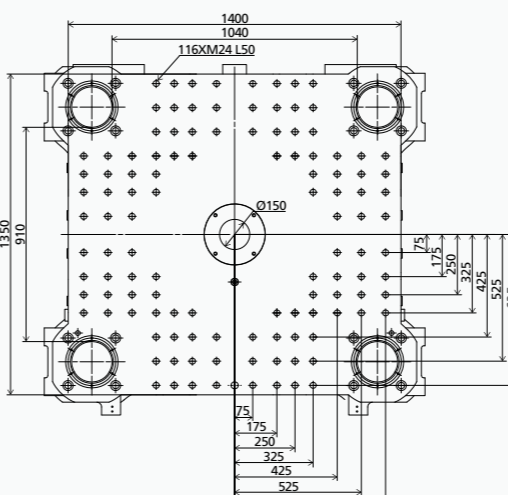

## MOVABLE PLATEN

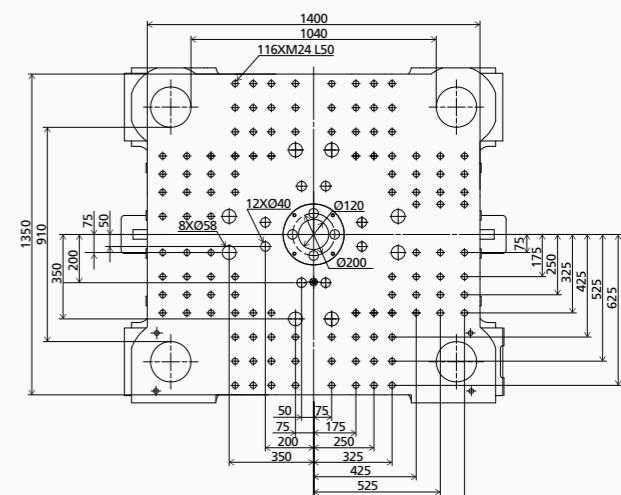

We reserve the right to make changes as a result of further technical advantages.

# PLATEN LAYOUT JE7500 III

EUROPEAN VERSION  
FIXED PLATEN

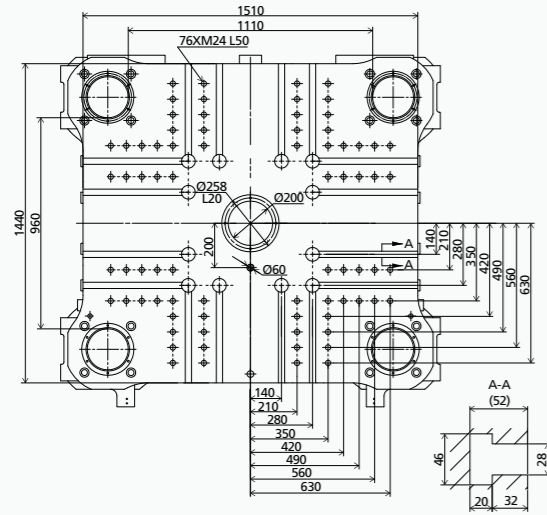

MOVABLE PLATEN

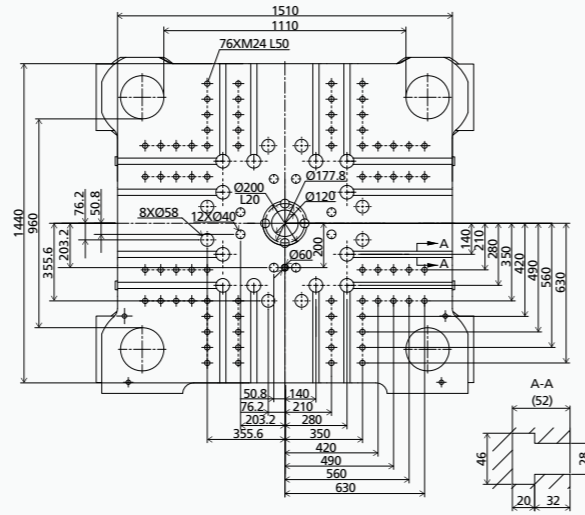

AMERICAN VERSION  
FIXED PLATEN

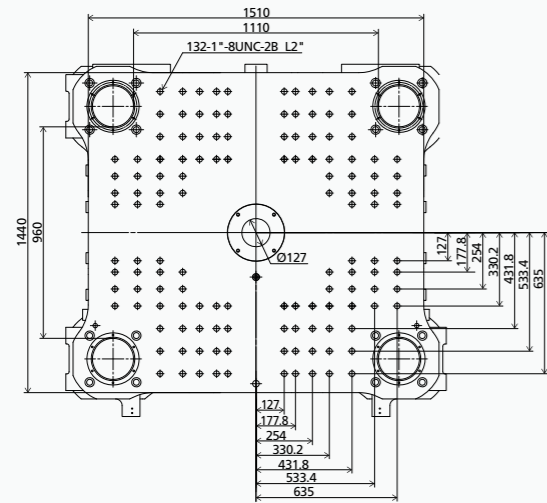

MOVABLE PLATEN

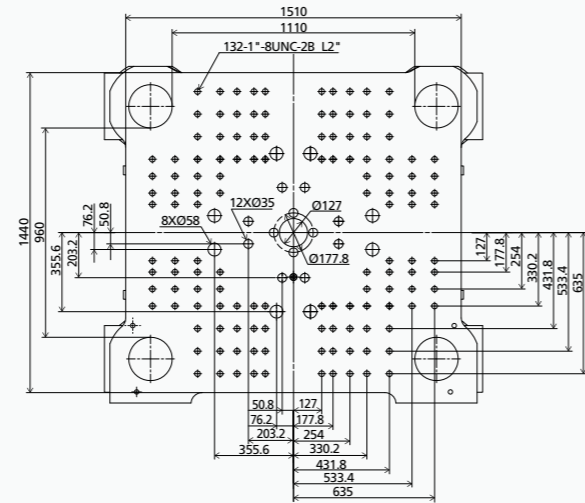

JAPANESE VERSION  
FIXED PLATEN

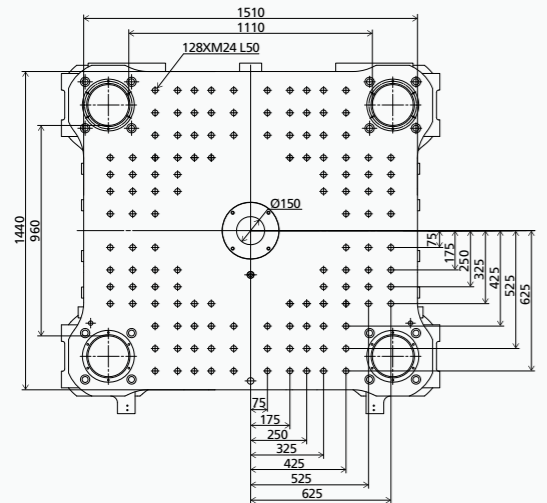

MOVABLE PLATEN

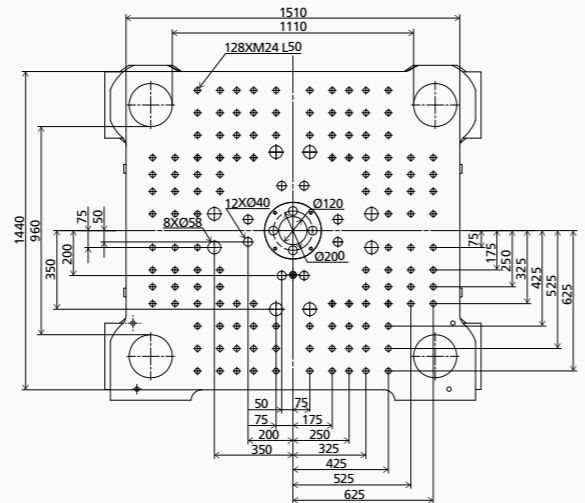

EUROPEAN VERSION  
FIXED PLATEN

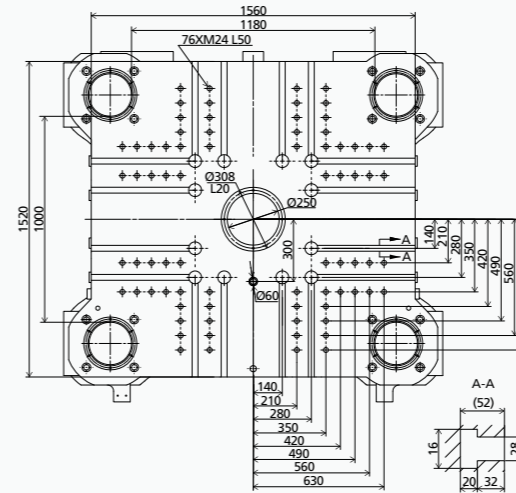

MOVABLE PLATEN

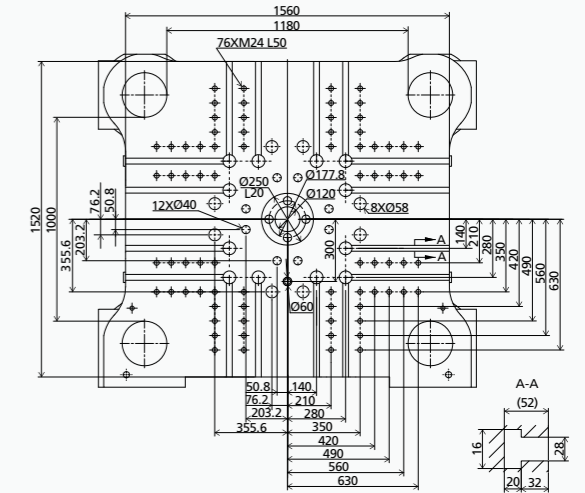

AMERICAN VERSION  
FIXED PLATEN

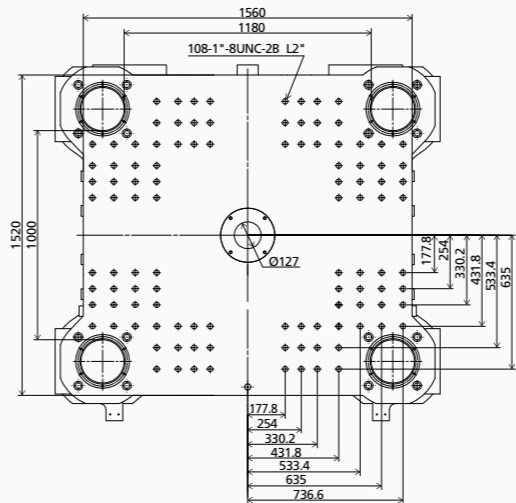

MOVABLE PLATEN

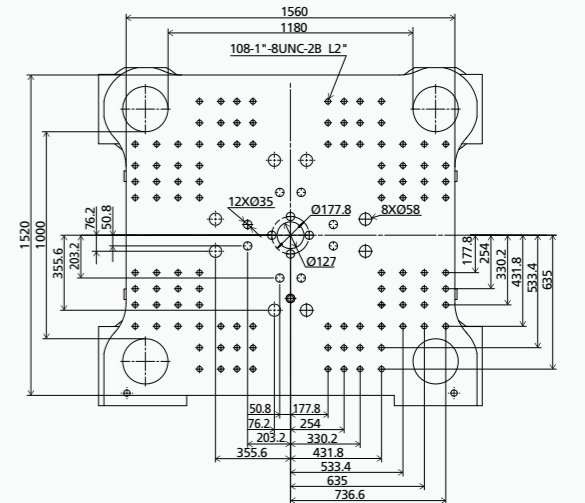

JAPANESE VERSION  
FIXED PLATEN

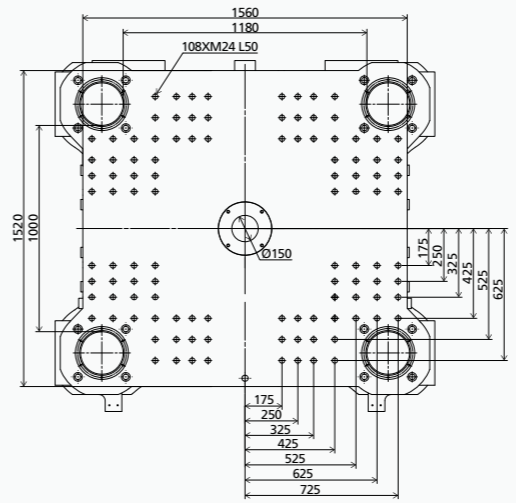

MOVABLE PLATEN

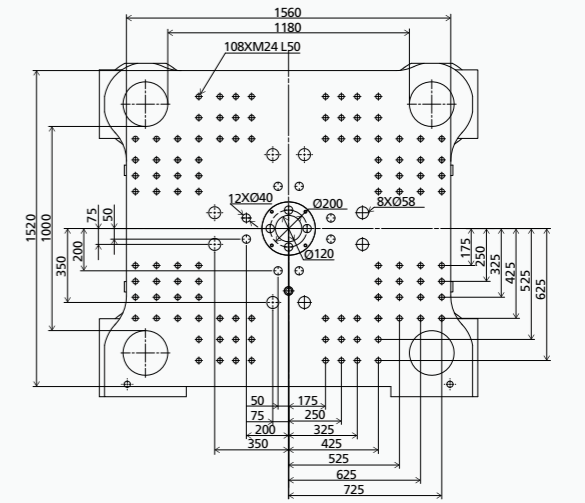

We reserve the right to make changes as a result of further technical advantages.

# PLATEN LAYOUT JE10800 III

## EUROPEAN VERSION FIXED PLATEN

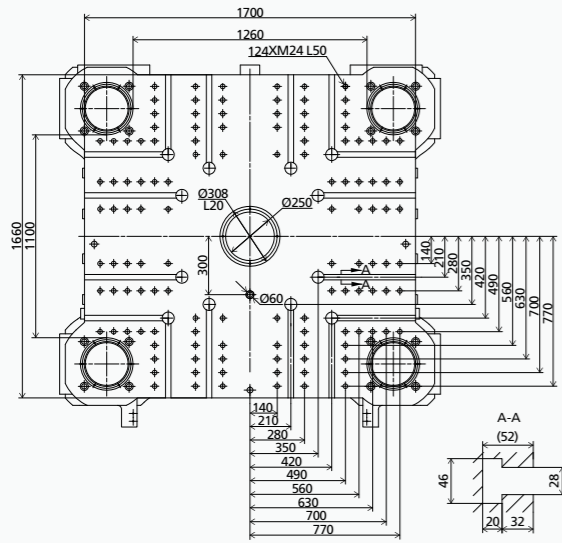

## MOVABLE PLATEN

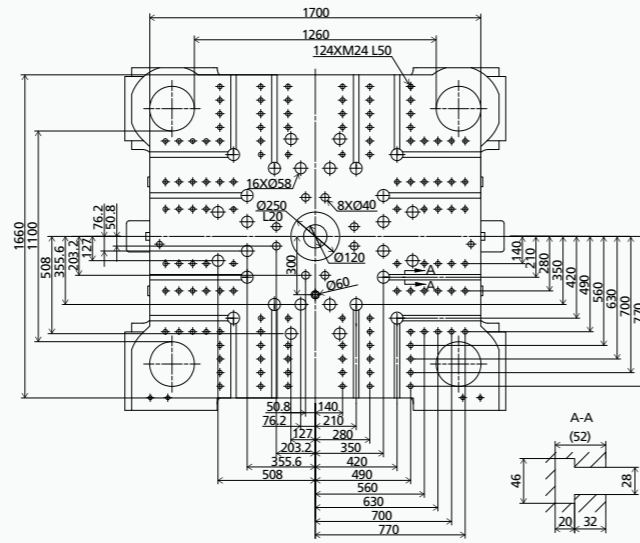

## AMERICAN VERSION FIXED PLATEN

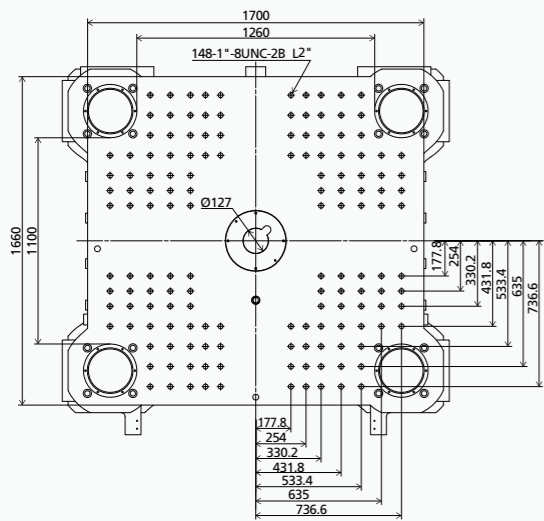

## MOVABLE PLATEN

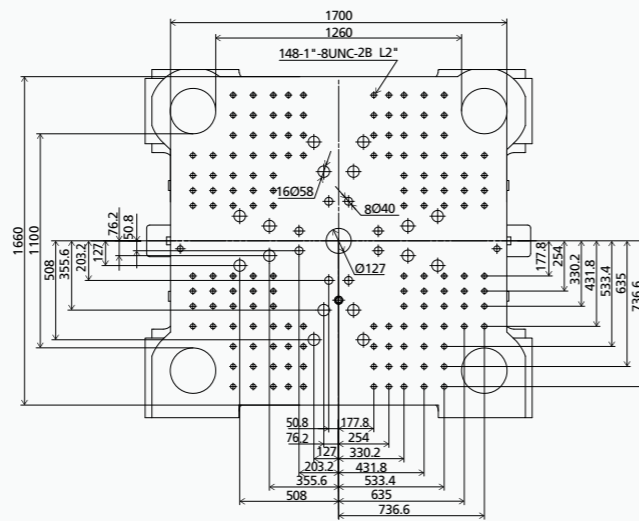

## JAPANESE VERSION FIXED PLATEN

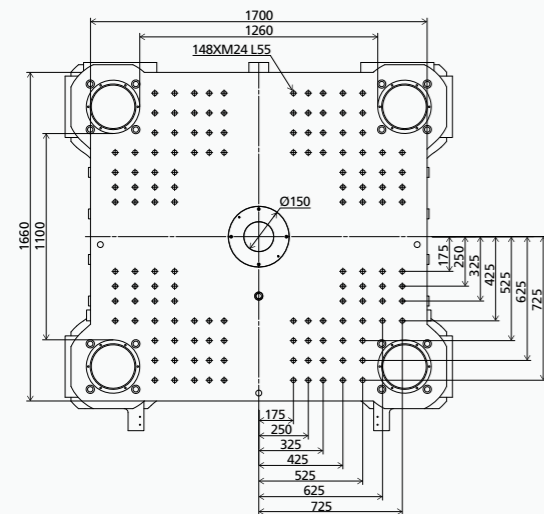

## MOVABLE PLATEN

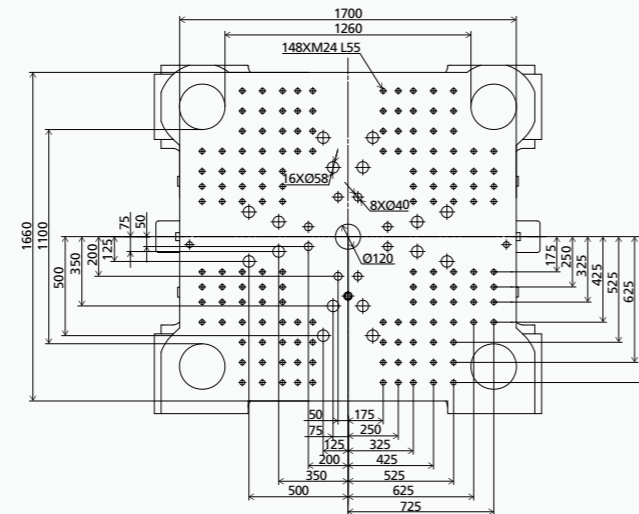

## NOTE:

We reserve the right to make changes as a result of further technical advantages.